



RM3155ADSW

55" inch Wall Mounted Digital Signage



★ FEATURES

- LG IPS 1080P HD high brightness screen
- Ultra thin border for easy multi-screen splicing
- Network remote management



RM3155ADSW

55" inch Wall Mounted Digital Signage



- LG original IPS 1080P HD high brightness screen
- Support standard VESA, horizontal or vertical installation
- Ultra thin border for better display and easy multi-screen splicing
- Network remote management, can transfer contents through computer, mobile phone or USB interface
- Support timing switch, network wake-up, screen dividing or multi-screen splicing
- Support Ethernet and WIFI

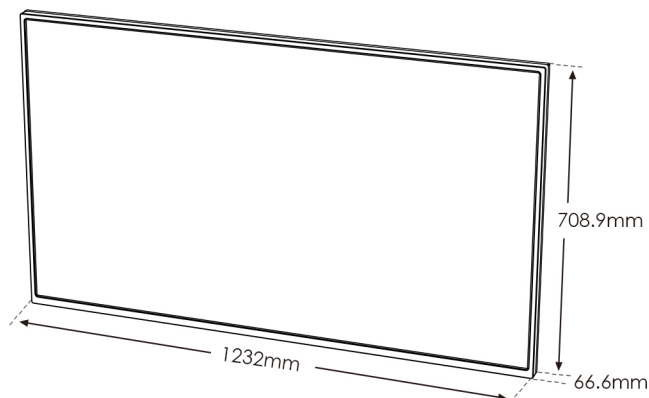
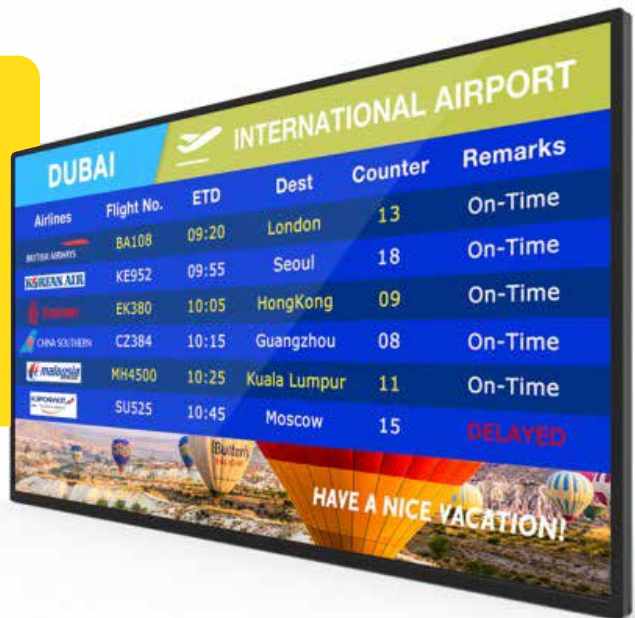



RM3155ADSW

55" inch Wall Mounted Digital Signage

SPECIFICATION

WIN7/10 (trial version)		CPU	Intel Celeron J1900 quad-core 2.0G	
		System Memory	4G	
		Disk	64G/128G/256G(SSD)	
		Speaker	5W*2	
		Interface	USB*4/RJ45*1	
		Network	Ethernet/WIFI	
Android 6.0 and higher version		CPU	A83T Cortex-A7 octa-core 2.0GHz	
		System Memory	1G/2G	
		Disk	8G/16G/32G/64G	
		Speaker	5W*2	
		Interface	USB*2/RJ45*1	
		Network	Ethernet/WIFI	
LCD	Type	TFT-LCD	Contrast Ratio	1100:1
	Screen size	55"	Response Time	12ms
	Max Resolution	1920×1080	Viewing Angle	H178° V178°
	Aspect Ratio	16:09	Display Colors	16.7M
	Brightness	400cd/m ²	Refresh Rate	60Hz
	Panel Life	50000 hours		
Power	Voltage	100-240VAC,50/60Hz	Power Consumption	<100W
Enclosure	Material	SPCC		
	Surface	Powder coating		
	Overall Size	55",L914×W400×H2015/L914×W400×H2075(with wheels)		
	Package	55", L2065×W840×H580		
	Net Weight	99kg(55")		
	Gross Weight	191kg(55")		
Application	Working temperature	0~40℃	Storage temperature	-20~60℃
	Working humidity	20%~80%	Storage humidity	10%~90%
	Application	indoor		

*Product specifications subject to change without prior notice